

St. Petersburg College

SIGN LANGUAGE INTERPRETATION PROGRAM CLEARWATER CAMPUS

Thank you for your interest in the Sign Language Interpretation Program (SLIP) at St. Petersburg College. The field of interpreting is challenging and interpreters are in great demand.

The Sign Language Interpretation Program (SLIP) is on the Clearwater Campus; however, a limited number of Sign Language classes are offered on the St. Petersburg/Gibbs, Seminole, Tarpon Springs, and Downtown campuses. This packet contains information about the program and about requirements for an associate of science degree in Sign Language Interpreter Training.

Learning American Sign Language (ASL I and ASL II) also meets the foreign language requirements of many colleges and universities.

If you have any questions regarding the program, please contact us at (727) 791-2609. The program office is located in the Language Arts Building in room 185.

Thank you for your inquiry.

<p align="center">ST. PETERSBURG COLLEGE Sign Language Interpretation Program (SLIP) SLIP Office: (727) 791-2609 FAX: (727) 791-5907</p>
--

Communications

Dean of Communications.....Dr. Martha Campbell
 Academic Chair.....Matt Bowen
 Administrative Assistant.....Joan Smith
 Staff Assistant.....Lara Holmes

Instructors

Instructor..... Sammie H. Elser
 Instructor:..... Frona Elkes
 Instructor:..... Mike Henry
 Instructor..... Dr. Beth Carlson
 Instructional Assistant Marika Robinson

Adjuncts

Debbie Henry	Michele Sacco-Eanes
Michael Yelapi	Teresa Kessie
Jenny Locy	Charon Aurand

**Sign Language Interpretation Program
 Advisory Board**

Jack Humburg, Chair	Charon Aurand
John Blaylock	Rosa Rodriguez
The Honorable Bruce Boyer	Noel Cherasaro
Linda Roberts	Dawnmarie Caggiano
Aaron Orange	Judy Jaeger
Mary Ann Zeigler	

SIGN LANGUAGE INTERPRETATION PROGRAM

A solid foundation for a rewarding career

St. Petersburg College (SPC) offers one of the most highly-respected Sign Language Interpretation Programs (SLIP) in the United States. A student who successfully completes the program earns an Associate in Science degree. For those taking a full class load, the program can be completed in two years.

SLIP is based on St. Petersburg College's Clearwater Campus which has a history of serving deaf/hard of hearing students. Therefore, for interpreter trainees a vast opportunity exists to experience deaf culture and a wide variety of sign language styles. In addition, SPC is in the Tampa Bay region which claims the fifth largest deaf population in the United States.

Interpreters are in demand. With the passage of the Americans with Disabilities Act, the need for skilled and qualified interpreters has increased and will continue to grow dramatically. The demand for trained interpreters far exceeds the supply.

Career opportunities abound. In addition to the many business opportunities, interpreters are hired by public and private employers including the following

educational organizations	community-based organizations
medical facilities	government agencies
law enforcement agencies	temporary agencies
churches and theatre productions	

Coursework

In addition to the general education courses, students will participate in specialized courses such as the following.

American Sign Language	Fundamentals of Interpreting
DeafCulture	Interpreting/Transliterating
Fingerspelling	Educational Interpreting
Structure of American Sign Language	Voice I and II
Practicum	Specialized Topics

Students also participate in an intense practicum and internship at SPC and other sites in the community and surrounding areas that provide first-hand experience under the supervision of mentors in the interpreting field.

The Jessica Lunsford Bill requires background screening for all personnel "who are permitted access on school grounds when students are present or for those who have direct contact with students".

Graduates of the program are encouraged to take the FRID QA to obtain credentials necessary for employment. Depending on the level achieved, an apprentice interpreter may be eligible to interpret in a variety of settings.

For more information about the Sign Language Interpretation Program, contact:

Sign Language Interpretation Program
Voice: (727) 791-2609
Fax: (727) 791-5907

**For general information about becoming a student at SPC,
call (727) 791-2609**

ESSENTIAL ELEMENTS THAT ARE PREREQUISITE TO BECOMING A SIGN LANGUAGE INTERPRETER FOR THE DEAF

Mental Demands made upon Sign Language Interpreters:

- Rapid mental processing
- Near-native proficiency in at least two languages
- Cognitive awareness of cultural norms
- Constant mental focus in a variety of settings

Physical Demands made upon Sign Language Interpreters:

- Facial Expressiveness: ability to appropriately match speaker tone
- Upper-body strength: ability to continually use hands and arms
- Physical stamina: ability to sign rapid lectures for a long periods of time
- Vocal strength and clarity: ability to project voice in a clear and easily understood manner, good public speaking skills
- Hearing acuity: ability to distinguish speech even in poor acoustic conditions
- Visual acuity: ability to distinguish using both near and far vision
- Physical dexterity: ability to rapidly use hands/fingers

Emotional Demands made upon Sign Language Interpreters

- Communication flexibility: ability to interact with diverse populations in a variety of settings
- Communication sensitivity: awareness of others and message intent, excellent people skills
- Emotional stability: ability to maintain a calm demeanor during stressful situations
- Interpersonal communication skills: acceptance of alternate view points
- Professional maturity: ability to professionally handle criticism/suggestions/comments regarding sign choice and style
- Emotional flexibility: ability to quickly adjust to last minute changes

Professional Responsibilities required of Sign Language Interpreters

- Self motivation
- Punctuality
- Confidentiality
- Professional appearance
- Desire to maintain and enhance communication skills through training

ST. PETERSBURG COLLEGE

REQUIRED COURSE SEQUENCE SIGN LANGUAGE INTERPRETATION COURSES

REQUIRED GENERAL EDUCATION COURSES MUST BE COMPLETED AS WELL.

The required program courses within the major leading to the degree of Associate in Science in Sign Language Interpretation Program must be taken in the order shown below. Each Roman numeral represents one academic session.

(INTRP-AS)

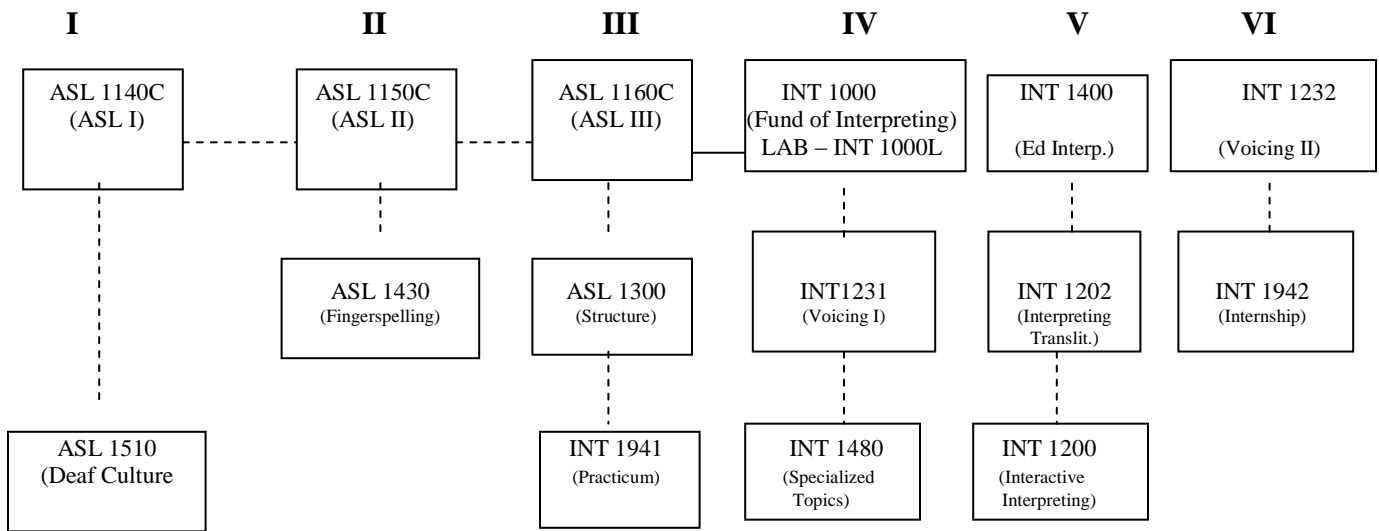

INTERPRETING COURSES MUST BE COMPLETED IN THE ORDER SHOWN ABOVE.

NOT ALL CLASSES ARE OFFERED EVERY SEMESTER.

STUDENTS ARE STRONGLY ENCOURAGED TO TAKE GENERAL EDUCATION COURSES IF THE STUDENTS ENTER THE PROGRAM DURING A FALL SESSION SO THAT THE STUDENTS CAN BEGIN THE PROGRAM SEQUENCE IN THE SPRING.

A grade of "C" or better in the above support and core courses is required.

SUGGESTED PLAN TO COMPLETE ASL AND INT COURSEWORK

STUDIES BEGIN IN FALL SESSION

<u>Fall Session</u>	<u>Spring Session</u>	<u>Summer Session</u>	<u>Fall Session</u>	<u>Spring Session</u>	<u>Summer Session</u>	<u>Fall Session</u>
ASL 1140C (ASL I)	ASL 1150C (ASL II)	ASL 1160C (ASL III)	ASL 1300 (Structure)	INT 1000 (Fund of Interpreting)	INT 1400 (Ed. Interp.)	INT 1232 (Voicing II)
	ASL 1510 (DeafCulture)	ASL 1430 (Finger Spelling)	INT 1941 (Practicum)	INT 1000L (Fund of Interpreting Lab)	INT 1202 (Interpreting Transliteration)	INT 1942 (Internship)
				INT 1231 (Voicing I)	INT 1200 (Interactive Interpreting)	
				INT 1480 (Specialized Topics)		

STUDIES BEGIN IN SPRING SESSION

<u>Spring Session</u>	<u>Summer Session</u>	<u>Fall Session</u>	<u>Spring Session</u>	<u>Summer Session</u>	<u>Fall Session</u>
ASL 1140C (ASL I)	ASL 1150C (ASL II)	ASL 1160C (ASL III)	INT 1000 (Fund of Interpreting)	INT 1400 (Ed. Interp.)	INT 1232 (Voicing II)
ASL 1510 (DeafCulture)	ASL 1430 (Finger Spelling)	ASL 1300 (Structure)	INT 1000L (Fund of Interpreting Lab)	INT 1202 (Interpreting Transliteration)	INT 1942 (Internship)
		EHD1941 (Practicum)	INT 1231 (Voicing I)	INT 1200 (Interactive Interpreting)	
			INT 1480 (Specialized Topics)		

STUDIES BEGIN IN SUMMER SESSION

<u>Summer Session</u>	<u>Fall Session</u>	<u>Spring Session</u>	<u>Summer Session</u>	<u>Fall Session</u>	<u>Spring Session</u>	<u>Summer Session</u>	<u>Fall Session</u>
ASL 1140C (ASL I)	ASL 1150C (ASL II)	ASL 1160C (ASL III)	ASL 1300 (Structure) ????	EHD1941 (Practicum)	INT 1000 (Fund of Interpreting)	INT 1400 (Ed. Interp.)	INT 1232 (Voicing II)
	ASL 1510 (DeafCulture)	ASL 1430 (Finger Spelling)		ASL 1300 (Structure)	INT 1000L (Fund of Interpreting Lab)	INT 1202 (Interpreting Transliteration)	INT 1942 (Internship)
					INT 1231 (Voicing I)	INT 1200 (Interactive Interpreting)	
					INT 1480 (Specialized Topics)		

Required program courses leading to an Associate in Science Degree in Sign Language Interpretation

Course I.	Description General Education Courses (21 credits)	Credit Hours	Session							
			I	II	III	IV	V	VI		
ENC1101-1102	Composition I and II	3/3								
Mathematics	One college-level course with a MAC, MGF, or MTG or STA prefix	3								
PHI1600	Applied Ethics OR (PHI1602H, 1631, 2635 or 2649)	3								
*Humanities/Fine Arts	Humanities/Fine Arts Approved Course	3								
POS2041	American National Government	3								
SPC1600	Intro to Speech Communication	3								
**Computer Literacy	Computer/Information Literacy Competency Requirement									
II. Support Courses (20 Credits)										
A grade of "C" or better is required.										
PSY1012	General Psychology OR	3 Or								
SYG2000	Introductory Sociology	3								
ASL1140C	Basic American Sign Language/Lab	4								
ASL1150C	Intermediate American Sign Language/Lab	4								
ASL1160C	Advanced American Sign Language/Lab	4								
ASL1510	Deaf Culture	3								
ASL1430	Fingerspelling	2								
III. Core Courses (31 Credits)										
A grade of "C" or better is required.										
INT1000	Fundamentals of Interpreting	2								
INT1000L	Fundamentals Lab	2								
INT1480	Interpreting Specialized Topics	3								
INT1400	Issues in Educational Interpreting	2								
INT1200	Interactive Interpreting	2								
INT1202	Interpreting/Transliterating	4								
INT1231	Voicing I	3								
INT1232	Voicing II	3								
INT1941	Interpreting Practicum	3								
INT1942	Interpreting Internship	4								
ASL1300	Structure of American Sign Language	3								

Total Hours 72

SIGN LANGUAGE (SPA/ASL) AND INTERPRETING (EHD) COURSES MUST BE COMPLETED IN A SPECIFIC ORDER.

NOT ALL COURSES ARE OFFERED EVERY SEMESTER.

A GRADE OF "C" OR BETTER IS REQUIRED IN ALL SIGN LANGUAGE (SPA) AND INTERPRETING (EHD) COURSES.

*See Special Requirements for the Associate in Science Degree for a list of courses that satisfy this requirement.

**See the list of Computer Literacy competency options under General Education Requirements for the A.S. Degree in the college catalog.

Sign Language Interpretation Course Descriptions

ASL 1140C BASIC AMERICAN SIGN LANGUAGE 4 credits

This is an introduction to American Sign Language (ASL) as used in the deaf community. There will be general discussion of ASL structure and introduction to a variety of manual communication systems and philosophies. Emphasis will be on building a basic vocabulary of approximately three hundred signs and the manual alphabet. Lab work is required. Five hours weekly.

ASL 1150C INTERMEDIATE AMERICAN SIGN LANGUAGE 4 credits

Prerequisites: SPA1612C/ASL1140C. This course is a continuation of the basic course; expands the student's signing skills and explores ASL idioms. Lab work is required. Five hours weekly.

ASL 1160C ADVANCED AMERICAN SIGN LANGUAGE 4 credits

Prerequisites: SPA1613C/ASL1150C, SPA1626/ASL1430 EHD1000/ASL1510, ENC0020, REA0020. This course is a continuation of Intermediate American Sign Language designed to develop signing skills to an advanced level. Included are idiomatic usage, cultural issues and professional option in deafness. Lab work is required. Five hours weekly.

ASL 1300 STRUCTURE OF AMERICAN SIGN LANGUAGE 3 credits

Prerequisites: SPA1613C/ASL1150C, SPA1626/ASL1430, EHD1000/ASL1510. This is a course for the intermediate or advanced signer with limited exposure to American Sign Language (ASL). American Sign Language, as used by deaf adults, is studied with an emphasis on the phonological, morphological, semantic, syntactical, idiomatic and metaphorical aspects of ASL. Current research in the field is examined and discussed. Three hours weekly.

ASL 1430 FINGERSPELLING 2 credits

Prerequisites: SPA1612C/ASL1140C, EHD1000/ASL1510. This course introduces students to fingerspelling and numbers in ASL. The course covers topics such as techniques and forms of fingerspelling, when people fingerspell and how they fingerspell to meet their needs. It also includes numerical systems in American Sign Language (ASL). Emphasis on both receptive and expressive development. Two hours weekly.

ASL 1510 INTRODUCTION TO DEAF CULTURE 3 credits

This course is an introduction and orientation to the educational, communicative, social, vocational, psychological and legal aspects of deafness. The course will deal with the impact of deafness on the individual and the family, as well as social patterns of the deaf community. In addition, it will describe historical and changing attitudes toward the culture of deaf persons and other groups of disabled persons. Three hours weekly.

INT 1000 FUNDAMENTALS OF INTERPRETING 2 credits

Prerequisites: SPA1614C/ASL1160C, SPA1626/ASL1430, SPA1617/ASL1300, EHD1941/INT1941.
Corequisite: INT 1400L. This course is an overview of the profession of interpreting, its standards and settings. It covers basic understanding of the Registry of Interpreters for the Deaf (RID) Code of Ethics which governs the standards of the interpreting profession and how to apply these principles to a variety of interpreting situations as well as other central issues related to the interpreting profession. Two hours weekly.

INT 1000L FUNDAMENTALS LAB 2 credits

Prerequisites: SPA1614C/ASL1160C, SPA1626/ASL1430, SPA1617/ASL1300, EHD1941/INT1941.
Corequisite: INT 1400. This course provides extensive hands-on practice to develop interpreting and transliterating skills. It includes extensive video and audio practice with different modes and sign codes. Four hours weekly.

INT 1480 INTERPRETING SPECIALIZED TOPICS 3 credits

Prerequisites: SPA1614C/ASL1160C, SPA1617/ASL1300, EHD1941/INT1941. This course will focus on the development of vocabulary and sign equivalents in specialized settings: medical, mental health, technical, religious, educational, theatrical; and other settings as deemed appropriate by the instructor; idiomatic and multi-meaning ASL/English words will be studied. Three hours weekly.

INT 1400 ISSUES IN EDUCATIONAL INTERPRETING 2 credits

Prerequisites: EHD 1400/INT1000, EHD 1400L/INT1000IL, EHD1401/INT1480, EHD 1406. This course explores the role of the interpreter in the educational setting. Issues related to institutional policies, potential role conflicts, interpreter/faculty collaboration, and support service provision will be emphasized. Two hours weekly.

INT 1200 INTERACTIVE INTERPRETING 2 credits

Prerequisites: EHD1400/INT1000, EHD 1400L/INT1000L, EHD1401/INT1480, EHD 1406. This course will focus on cognitive, linguistic and motor skill development in interactive interpreting; sign to voice and voice to sign skill mastery. Situations will simulate experiences encountered in one on one and interview settings, small group dynamics. Emphasis will be on simultaneous interpreting; consecutive style will also be included. Focus activities include audio/video and live model demonstrations, and out of class observations of certified/qualified interpreters in different settings. Two hours weekly.

INT 1202 INTERMEDIATE INTERPRETING/ TRANSLITERATING 4 credits

Prerequisites: EHD1400/INT1000, EHD1400L/INT1000L, EHD1401/INT1480, EHD1406/INT12341. The course is a continuation of EHD 1400 and EHD 1400L. This course reinforces skill development and the principles of interpreting from the source language of English to the target language of American Sign Language; and the principles of transliterating from the source language of English to the target language of signed codes of English. Activities will be reinforced through drill, practice, and role play demonstration, video and audio taped activities. The student will learn the techniques of self-assessment through videotaped assessment and class discussion/analysis. Four hours weekly.

INT 1231 VOICING I 3 credits

Prerequisites: SPA1614C/ASL1160C, SPA1617/ASL1300, EHD1941/INT1941. This course focuses on the development of primary voicing skills in interpreting for the deaf. Limited emphasis is given to interpreting from American Sign Language to spoken English. Voicing from signed English to spoken English and varying modalities are the focus of this course. Three hours weekly.

INT 1232 VOICING II 3 credits

Prerequisites: EHD1402/INT1400, EHD1403/INT1200, EHD1404/INT1202, EHD1406/INT1231, EHD1941/INT1941. This course focuses on the development of more advanced voicing skills in interpreting for the deaf. Special emphasis is given to interpreting from American Sign Language to spoken English as the focus of this course. Three hours weekly.

INT 1941 INTERPRETING PRACTICUM 3 credits

Prerequisites: SPA1613C/ASL1160C, SPA1626/ASL1430, EHD1000/ASL1510. This course provides the intermediate to advanced interpreting student with an opportunity to observe the interpreting process in various professional work situations. Students will schedule a series of individual and group observations, and discuss their practicum experiences during class. Guest speakers will also be a part of class activities. Three hours weekly.

INT 1942 INTERPRETING INTERNSHIP 4 credits

Prerequisites: EHD1402/INT1400, EHD1403/INT1200, EHD1404/INT1202. This course provides the advanced level interpreting student with an opportunity to participate at the entry level of the interpreting process in a variety of settings, with supervision. Students will schedule regular hours with affiliate agencies and, according to their level of interpreting skill, assist agency staff in normal duties. Supervision, observation, and evaluation will be provided by agency interpreting staff and interpreting instructors. Two hundred forty contact hours.